

GB

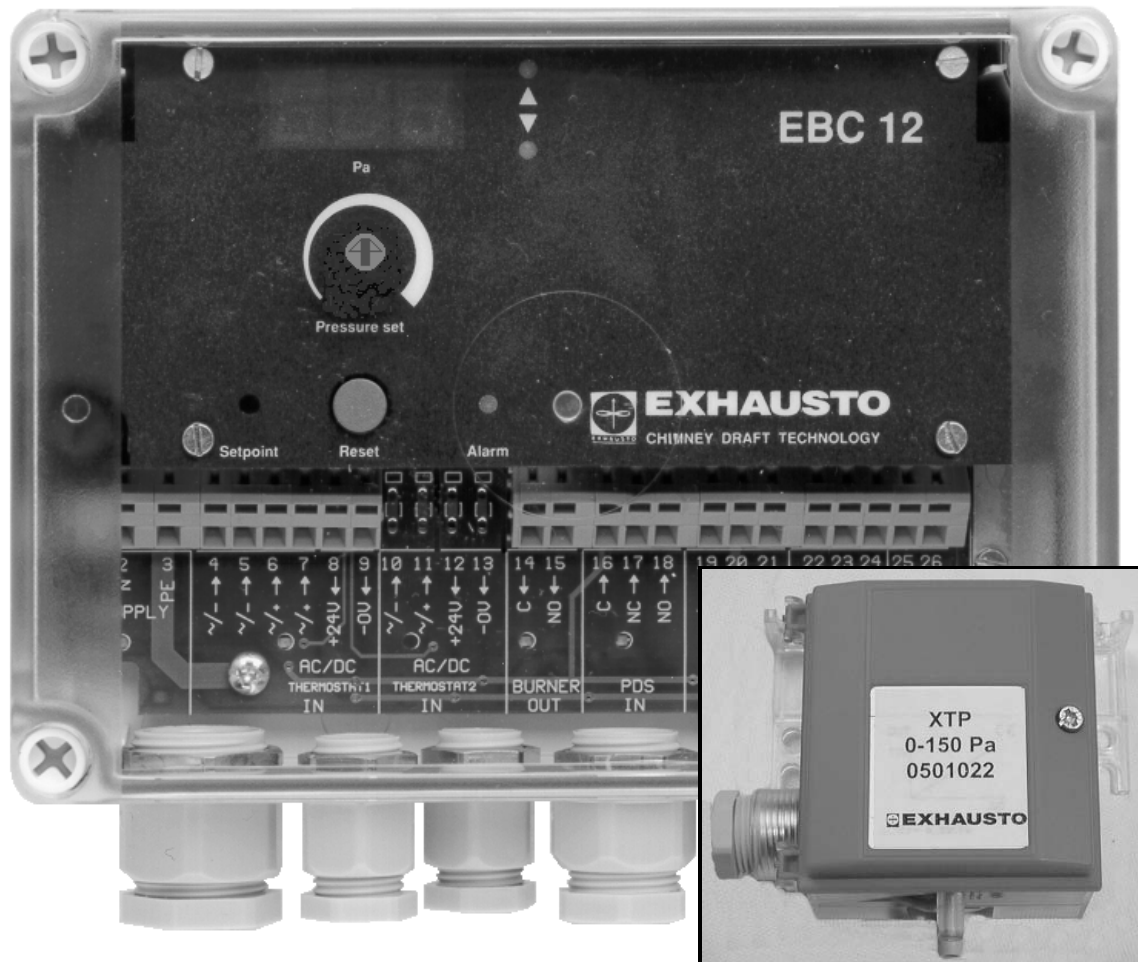

# EBC12-EU-01

EXHAUSTO A/S  
Odensevej 76  
DK-5550 Langeskov

Tel. +45 65 66 12 34  
Fax +45 65 66 11 10  
exhausto@exhausto.dk  
www.exhausto.dk

**EXHAUSTO**

FOR A BETTER FLOW



<b>1</b>	<b>Product information</b>	<b>3</b>
<b>2</b>	<b>Installation</b>	<b>4</b>
2.1	Fitting	4
2.2	Wiring	4
2.2.1	Connection examples	5
2.2.2	Example 1 - Voltage signal (fig. 5)	5
2.2.3	Example 2 - Voltage free contact (fig. 6)	6
2.2.4	Example 3 - Extra fail-safe supervision with pressure differential switch (fig. 7)	7
2.2.5	Example 4 - Continuous chimney fan operation (fig. 8)	8
2.3	Installation	9
2.3.1	Dipswitch setting (fig. 9-A)	9
2.4	Commissioning	10
<b>3</b>	<b>Fault finding</b>	<b>11</b>
<b>4</b>	<b>Technical data</b>	<b>12</b>

# 1 Product information

EBC12 (fig. 1) is an automatic control unit with constant pressure regulation of EXHAUSTO chimney fans. EBC12 is used for multiple systems and for boilers with a modulating burner. The automatic controls the chimney draught and cut out the boilers in case of a fault. The automatic control unit is used for both atmospheric gas boilers and for boilers with a forced draught burner for oil and gas.

### Function

When the boiler thermostat calls for heat, the chimney fan starts at full voltage. When the fail-safe supervision confirms sufficient chimney draught, the burner is released and the voltage to the chimney fan is regulated to match the draught selected (the value can be read from the display by pushing a button, fig. 1-B).

If the draught is in adequate for more than 12 seconds, the burner will cut out. Inadequate draught means that the pressure is less than 64% of the selected value, corresponding less than 80% flow.

When the boiler cuts out, the chimney fan stops, too. However, it is possible to select a 3-minute post-run period by means of the POST PURGE dipswitch (fig. 1-H). Alternatively, the controls can be wired so the chimney fan run continuously.

All in- and outputs have an LED for fail-safe supervision and servicing the system (fig. 1-I).

### Additional function

The controls have two extra safety functions which can be selected on the dipswitch (fig. 1-H), where this is prescribed by local regulations

- MANUAL RESET after power failure and draught fault.
- PDS-CHECK, only used for extra fail-safe function (pressure differential switch/PDS).
- EBC12 has a 0-10V output signal for controlling several chimney fans via a frequency converter or a motor power relay.

### Accessories

EBC12 comes with a pressure transducer (XTP-sensor), a tube and a probe.

- Fig. 1A: Fuse holder
- Fig. 1B: Setpoint button
- Fig. 1C: Reset button
- Fig. 1D: Potentiometer for adjusting the setpoint
- Fig. 1E: Display showing the current under pressure or setpoint
- Fig. 1F: Alarm LED (red)
- Fig. 1G: Up/down regulation LEDs (yellow)
- Fig. 1H: Dipswitch block
- Fig. 1I: ON/OFF LEDs (green)

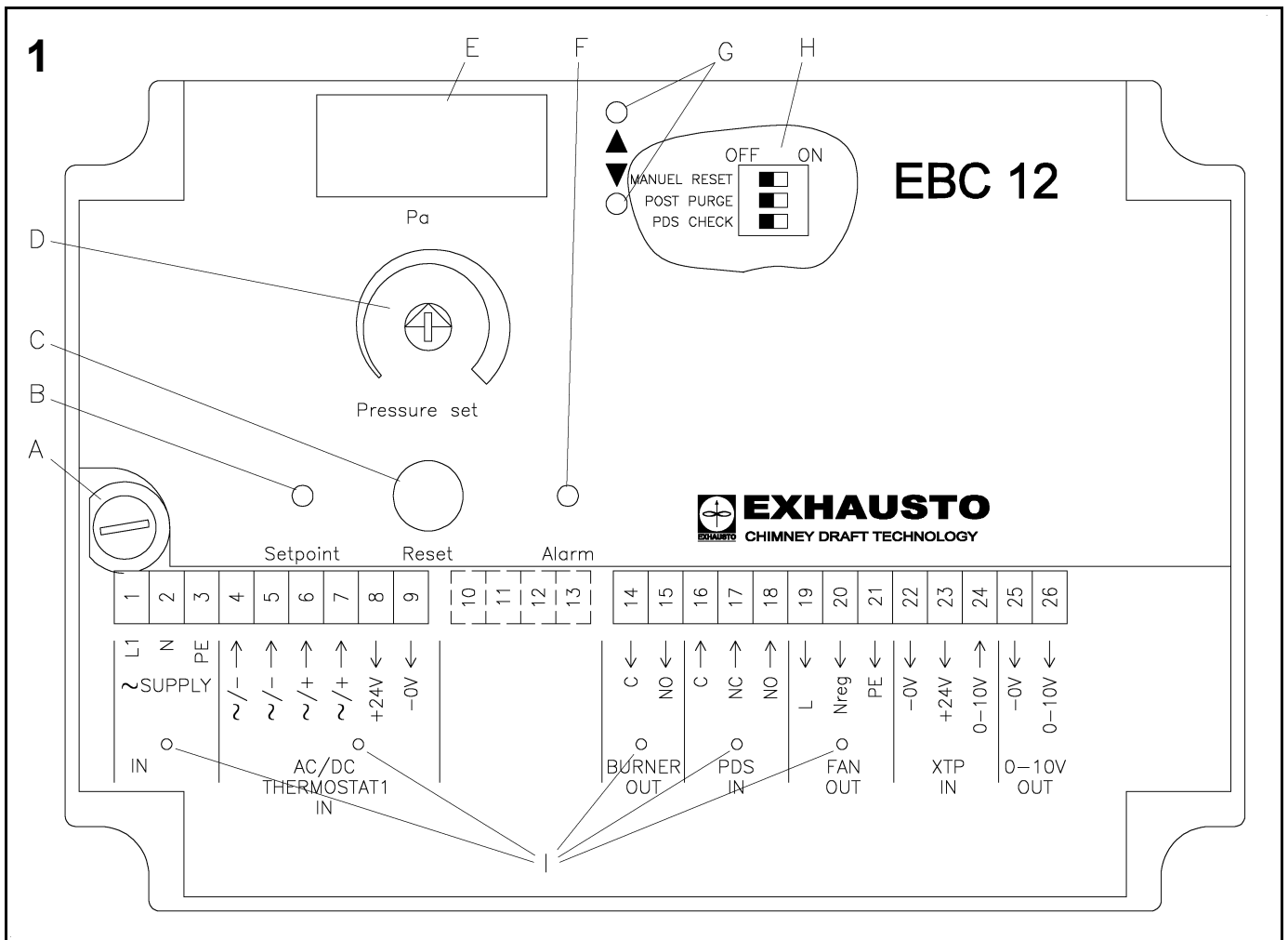

## 2 Installation

### 2.1 Fitting

Fit the control and the pressure transducer in the boiler room. The XTP-sensor's probe (fig. 2-A) must be mounted in the boiler's fluepipe or manifold. If the boiler is atmospheric the probe must always be placed after the hood. When mounted outdoor the sensor is to be mounted safe from wind and weather influences. The sensor can be mounted in a box with a hole (Ø2 mm) in the bottom, mainly to ensure correct reference pressure, but also to prevent water penetration.

If the sensor is mounted to that insects have direct access to the free (+) tube we recommend that a sinter filter is mounted.



Do not enclose the pressure transducer, as the atmospheric pressure is the reference pressure.

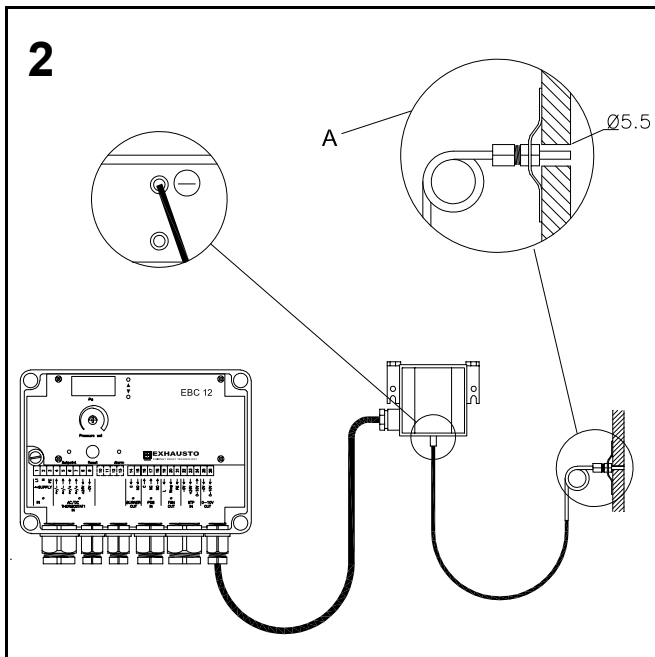

NB! Remember to turn the pressure transducer correctly (fig. 3).

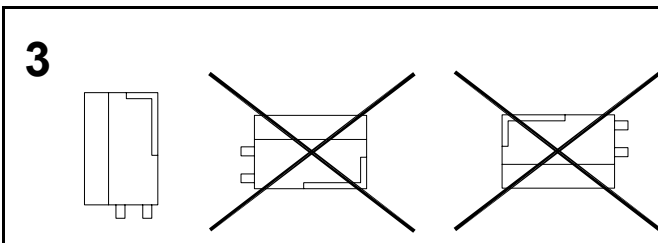

### 2.2 Wiring

The control terminals are spring-loaded. Use a suitable size of screwdriver for fitting the conductors. Fig. 4 shows how to fit the wires.

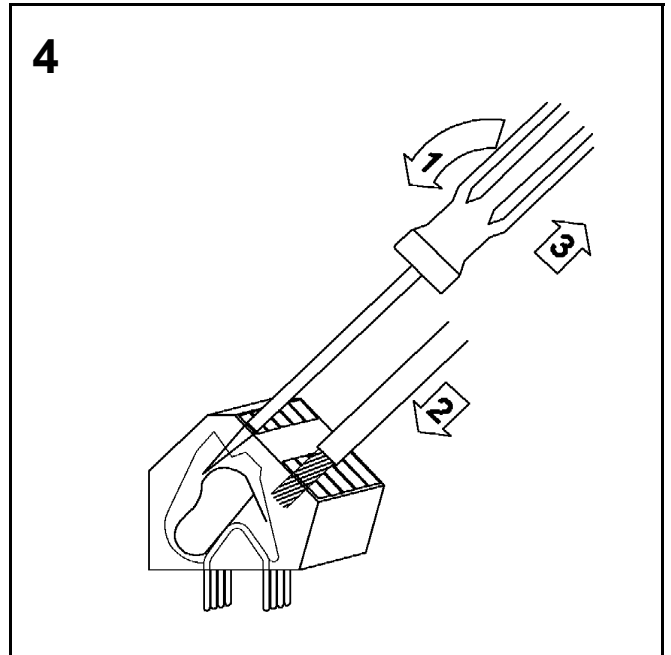

**2.2.1 Connection examples**

The controls can be connected to a voltage signal as well as a voltage free set of contacts - see connection example 1 or 2. It is recommended to contact the boiler manufacturer to ensure correct connections to the boiler automatic control unit.

Connection example 3 shows an EBC12 connected to a separate pressure differential switch (PDS). When the pressure differential switch has been connected, the boiler system has doubled its draught fail-safe function (the pressure differential switch is an accessory).

Connection example 4 shows continuous operation of the chimney fan.

**2.2.2 Example 1 - Voltage signal (fig. 5)**

The example shows how a voltage signal (10-230V AC/DC) from the boiler control is connected to the EBC12.

- Connect the power supply to terminals 1-3.
- Connection to the boiler automatic:
  - Connect the burner start signal (L) to terminal 6.
  - Loop terminals 7 and 14.
  - The start signal to the burner will now come on terminal 15.
  - Connect Neutral to terminal 4.
- Connect the chimney fan to terminals 19-21.
- Connect the pressure transducer (XTP) to terminals 22-24.

**Terminals (fig. 5)**

- 1 Supply L1
- 2 Supply N
- 3 Supply PE
- 4-5 Boiler thermostat. Opto coupler (-)(10-230V)
- 6-7 Boiler thermostat. Opto coupler (+)(10-230V)
- 8 24V DC supply to voltage free contact (boiler thermostat)
- 9 0V DC supply to voltage free contact (boiler thermostat)
- 14 Burner relay switch Common (max. 230V AC 8A)
- 15 Burner relay switch Normally Open (max. 230V AC 8A)
- 16 PDS-C (Common) pressure differential switch
- 17 PDS-NC (Normally Closed) pressure differential switch
- 18 PDS-NO (Normally Open) pressure differential switch
- 19 Chimney fan L1
- 20 Chimney fan Nreg
- 21 Chimney fan PE
- 22 XTP 0V supply (pressure transducer)
- 23 XTP 24V supply (pressure transducer)
- 24 XTP 0-10V signal (pressure transducer)
- 25 Control signal 0V
- 26 Control signal 0-10V

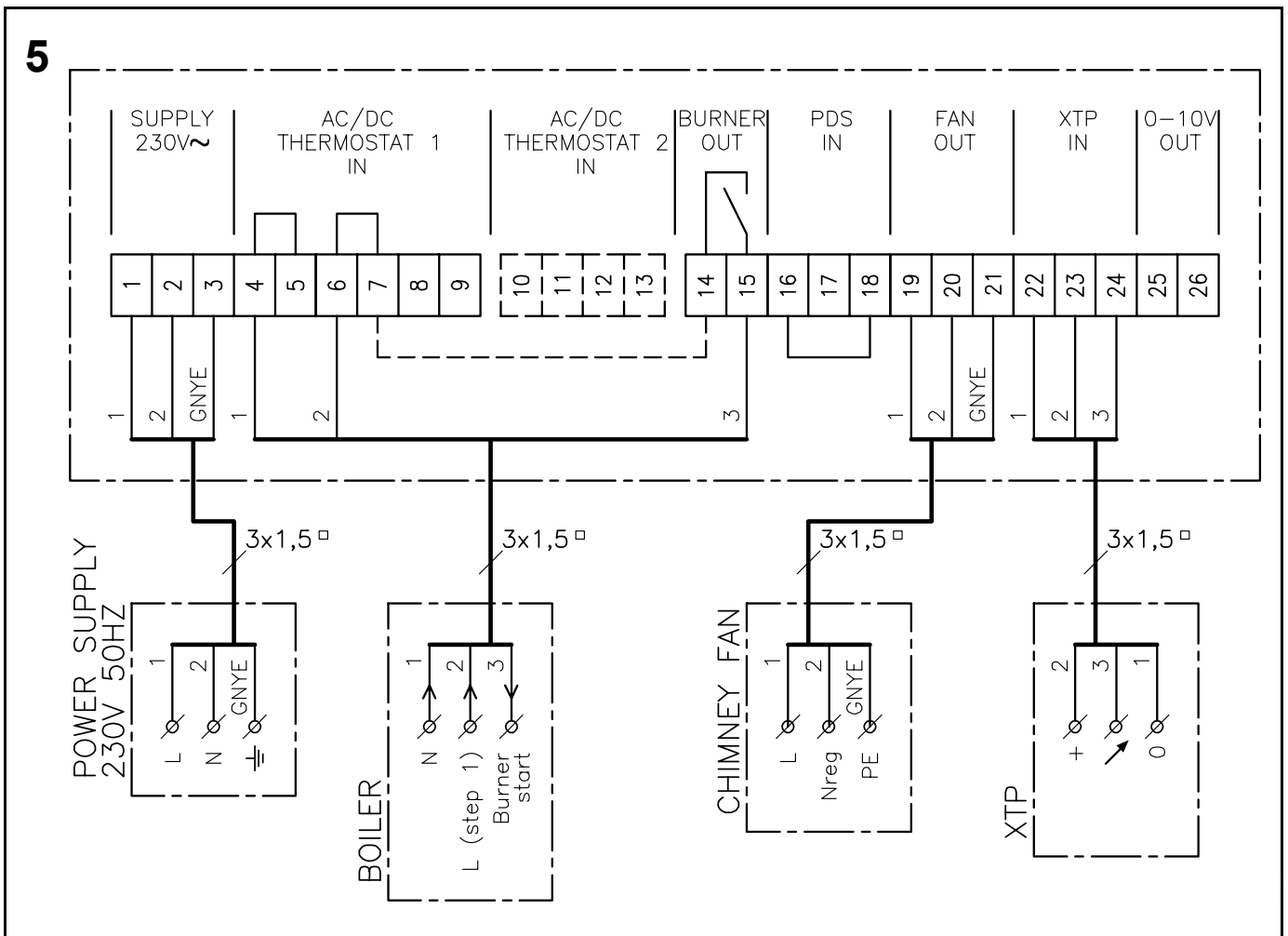

**2.2.3 Example 2 - Voltage free contact (fig. 6)**

The example shows how a voltage free contact from the boiler control is connected to the EBC12.

- Connect the power supply to terminals 1-3.
- Connection to the boiler automatic:
  - Connect the voltage free contact to terminals 4 and 9.
  - Loop terminals 7 and 8.
  - Connect the burner start signal to terminals 14 and 15.
- Connect the chimney fan to terminals 19-21.
- Connect the pressure transducer (XTP) to terminals 22-24.

Terminals (fig. 6)

- 1 Supply L1
- 2 Supply N
- 3 Supply PE
- 4-5 Boiler thermostat. Opto coupler (-)(10-230V)
- 6-7 Boiler thermostat. Opto coupler (+)(10-230V)
- 8 24V DC supply to voltage free contact (boiler thermostat)
- 9 0V DC supply to voltage free contact (boiler thermostat)
- 14 Burner relay switch Common (max. 230V AC 8A)
- 15 Burner relay switch Normally Open (max. 230V AC 8A)
- 16 PDS-C (Common) pressure differential switch
- 17 PDS-NC (Normally Closed) pressure differential switch
- 18 PDS-NO (Normally Open) pressure differential switch
- 19 Chimney fan L1
- 20 Chimney fan Nreg
- 21 Chimney fan PE
- 22 XTP 0V supply (pressure transducer)
- 23 XTP 24V supply (pressure transducer)
- 24 XTP 0-10V signal (pressure transducer)
- 25 Control signal 0V
- 26 Control signal 0-10V

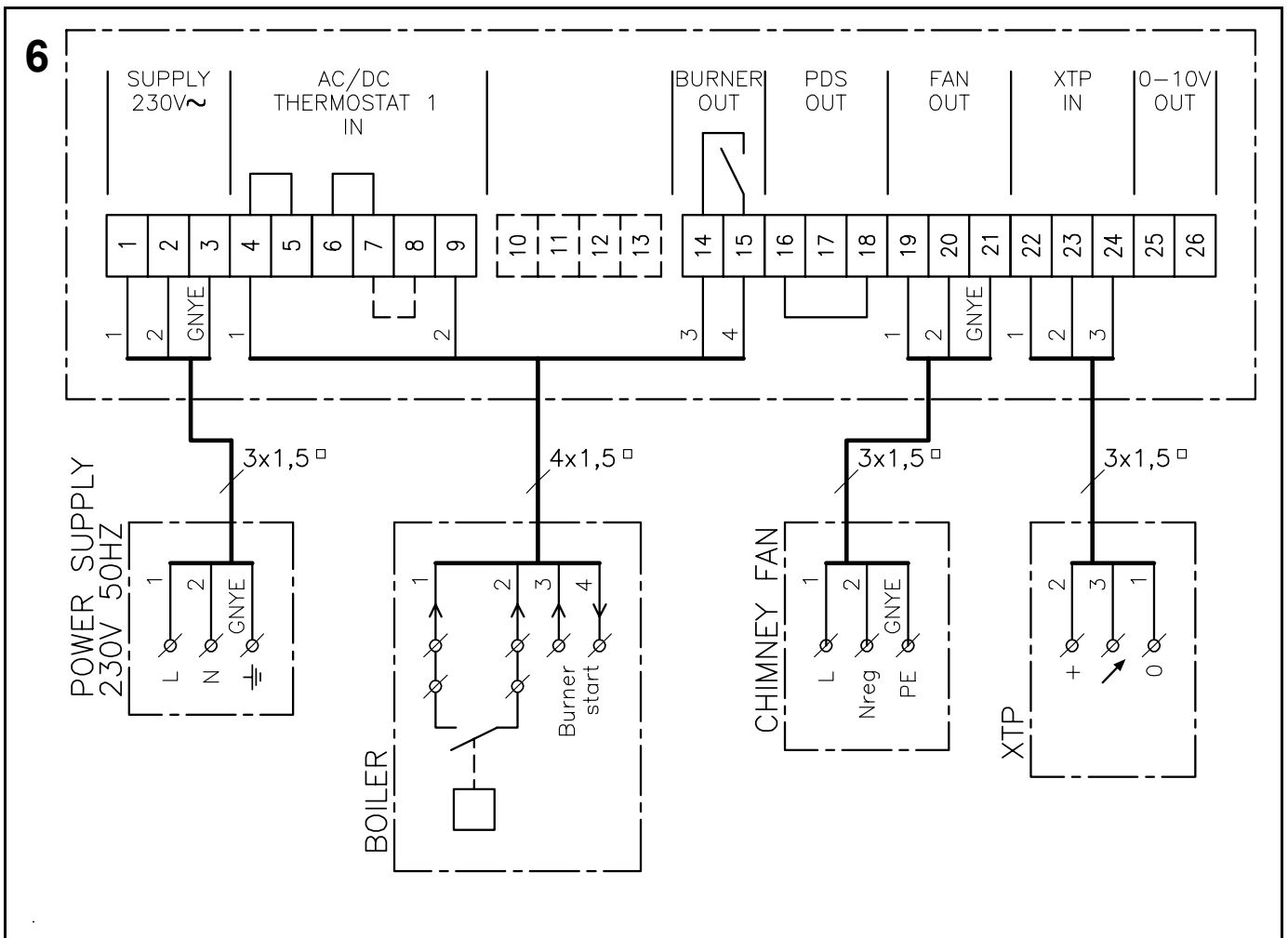

**2.2.4 Example 3 - Extra fail-safe supervision with pressure differential switch (fig. 7)**

The example shows how a pressure differential switch (PDS) must be connected to an EBC12. The pressure differential switch carries out extra fail-safe supervision. With a PDS fitted, the boiler will not be released, until both the pressure differential switch (PDS) and the pressure transducer (XTP) have registered sufficient draught.

- Connection to the pressure differential switch (PDS):
  - Remove the factory-fit loop between terminals 16 and 18.
  - Connect the pressure differential switch to terminals 16-18.
  - Connect the chimney fan to terminals 19-21. Chimney fans with an integral pressure differential switch (PDS) must be connected to terminals 16-21 according to the instructions enclosed with the chimney fan.
- The remaining terminals should be connected as in example 1 or 2.  
Below the connections of example 1 are shown.

Terminals (fig. 7)

- 1 Supply L1
- 2 Supply N
- 3 Supply PE
- 4-5 Boiler thermostat. Opto coupler (-)(10-230V)
- 6-7 Boiler thermostat. Opto coupler (+)(10-230V)
- 8 24V DC supply to voltage free contact (boiler thermostat)
- 9 0V DC supply to voltage free contact (boiler thermostat)
- 14 Burner relay switch Common (max. 230V AC 8A)
- 15 Burner relay switch Normally Open (max. 230V AC 8A)
- 16 PDS-C (Common) pressure differential switch
- 17 PDS-NC (Normally Closed) pressure differential switch
- 18 PDS-NO (Normally Open) pressure differential switch
- 19 Chimney fan L1
- 20 Chimney fan Nreg
- 21 Chimney fan PE
- 22 XTP 0V supply (pressure transducer)
- 23 XTP 24V supply (pressure transducer)
- 24 XTP 0-10V signal (pressure transducer)
- 25 Control signal 0V
- 26 Control signal 0-10V

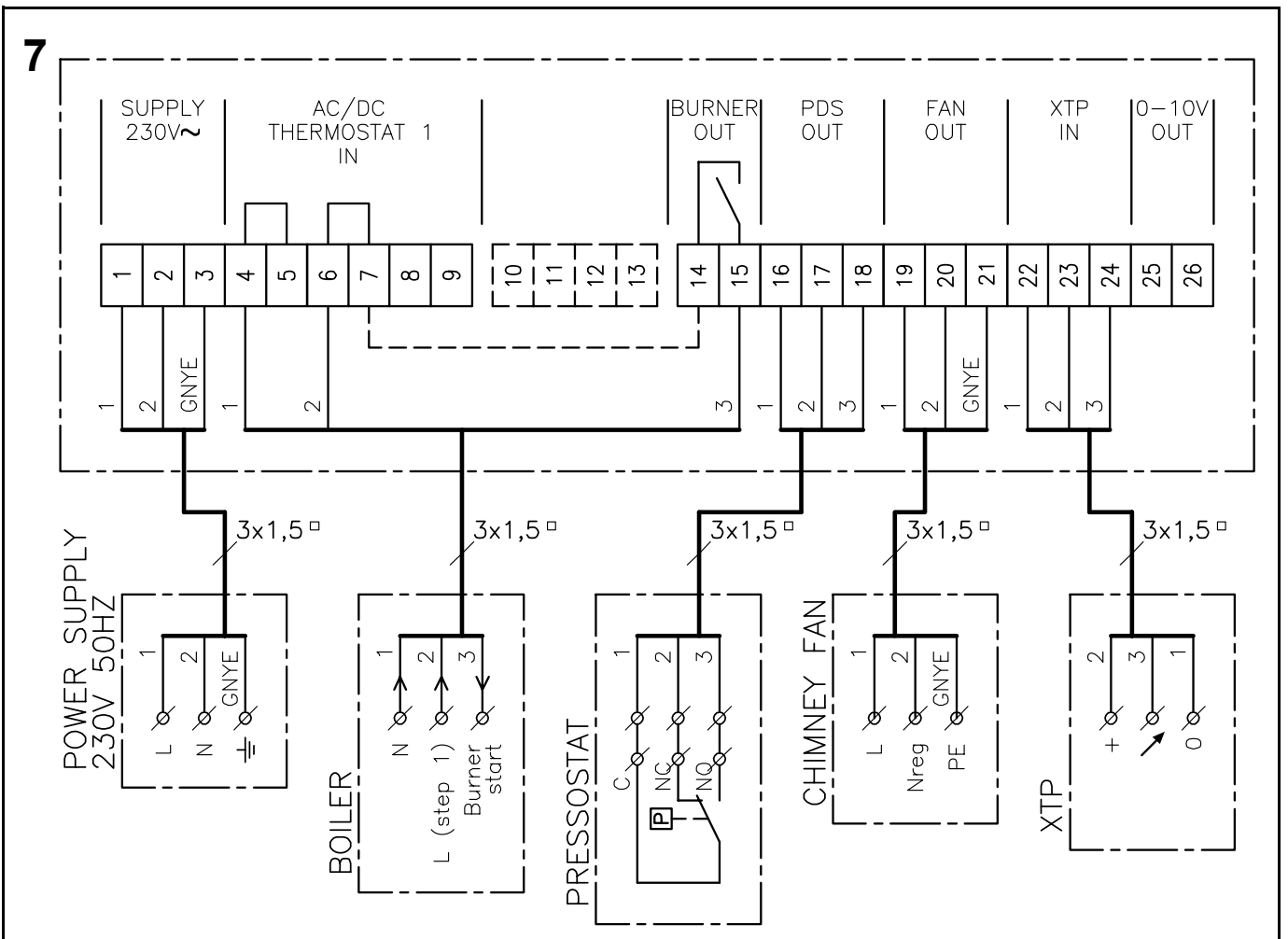

**2.2.5 Example 4 - Continuous chimney fan operation (fig. 8)**

This example shows how the EBC12 is to be connected if continuous chimney fan operation is required.

- Connect the power supply to terminals 1-3.
- Loop terminals 4 and 9.
- Loop for terminals 6 and 8.
- Connect the release signal to terminals 14 and 15.
- Connect the chimney fan to terminals 19-21.
- Connect the pressure transducer (XTP) to terminals 22-24.

Terminals (fig. 8)

- 1 Supply L1
- 2 Supply N
- 3 Supply PE
- 4-5 Boiler thermostat. Opto coupler (-)(10-230V)
- 6-7 Boiler thermostat. Opto coupler (+)(10-230V)
- 8 24V DC supply to voltage free contact (boiler thermostat)
- 9 0V DC supply to voltage free contact (boiler thermostat)
- 14 Burner relay switch Common (max. 230V AC 8A)
- 15 Burner relay switch Normally Open (max. 230V AC 8A)
- 16 PDS-C (Common) pressure differential switch
- 17 PDS-NC (Normally Closed) pressure differential switch
- 18 PDS-NO (Normally Open) pressure differential switch
- 19 Chimney fan L1
- 20 Chimney fan Nreg
- 21 Chimney fan PE
- 22 XTP 0V supply (pressure transducer)
- 23 XTP 24V supply (pressure transducer)
- 24 XTP 0-10V signal (pressure transducer)
- 25 Control signal 0V
- 26 Control signal 0-10V

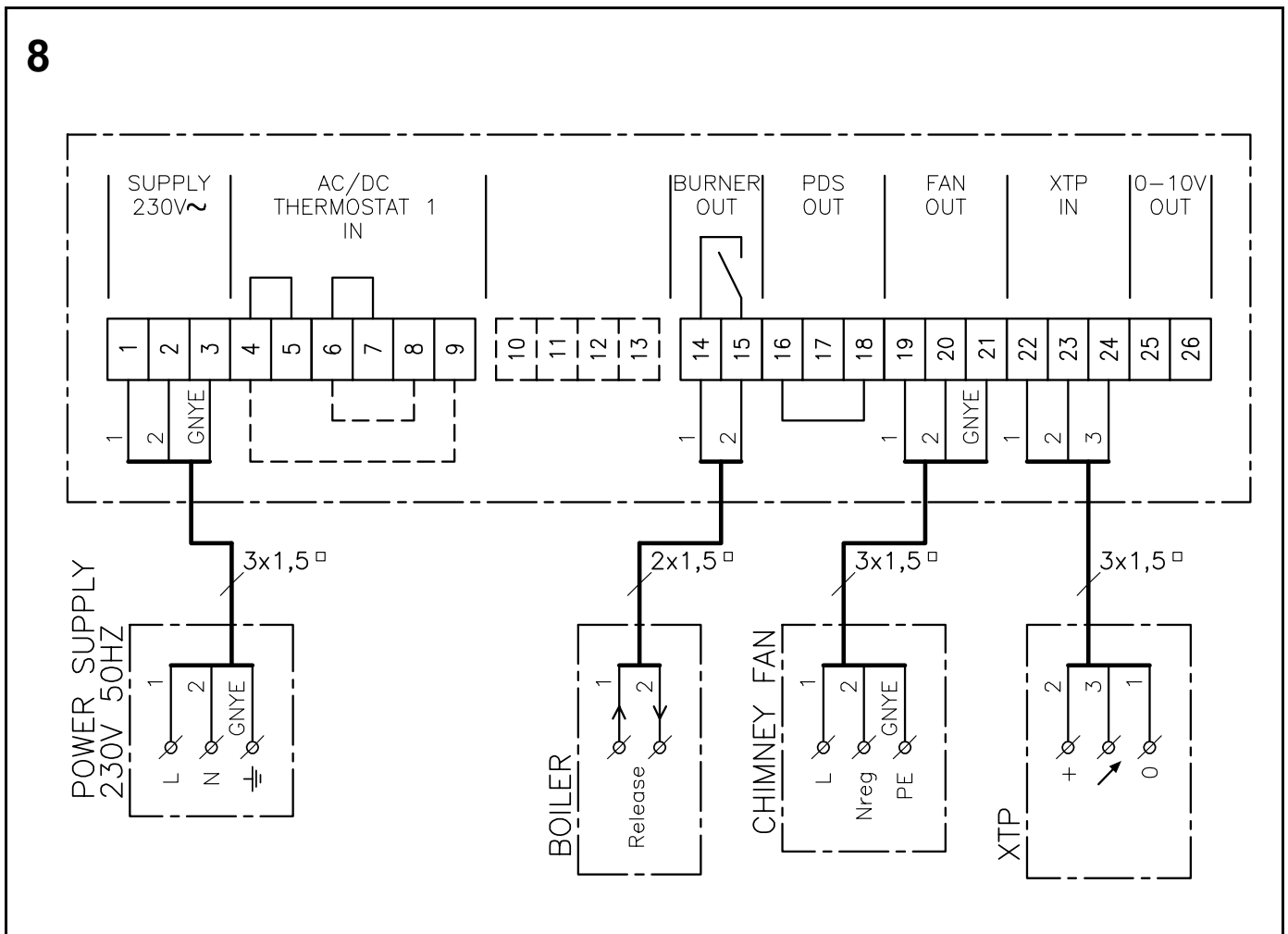



**2.3 Installation**

Before installation, read through item 2.3.1.

If the boilers are not connected to an electronic sequencer or management system we recommend the EXHAUSTO Relay Box ES12-EU-01 to interface a maximum of 4 boilers, use multiple relay boxes for more boilers. Please refer to the Instruction Manual on ES12-EU-01 for wiring details.

**2.3.1 Dipswitch setting (fig. 9-A)**

Before starting up the system, check that the dipswitch setting corresponds to the required operating mode.

**Factory setting: All OFF**

\*) Must always be in OFF position if the extra pressure differential switch (PDS) has not been connected.

If the factory setting is to be changed, the black top plate must be removed to get access to the dipswitch block (see fig. 9).

1. Remove the 4 serrated screws and lift the top plate off the PCB.
2. Change the dipswitch setting.

Dip-switch	Name	OFF	ON
1	MANUAL RESET	Automatic reset after mains drop-out and draught fault	Manual reset after mains drop-out and draught fault
2	POST PURGE	No post-purge	3-minutes post-purge
3*)	PDS CHECK	No control indicating that the pressure differential switch has been in position NC before starting up.	The pressure differential switch must be in position NC before starting up

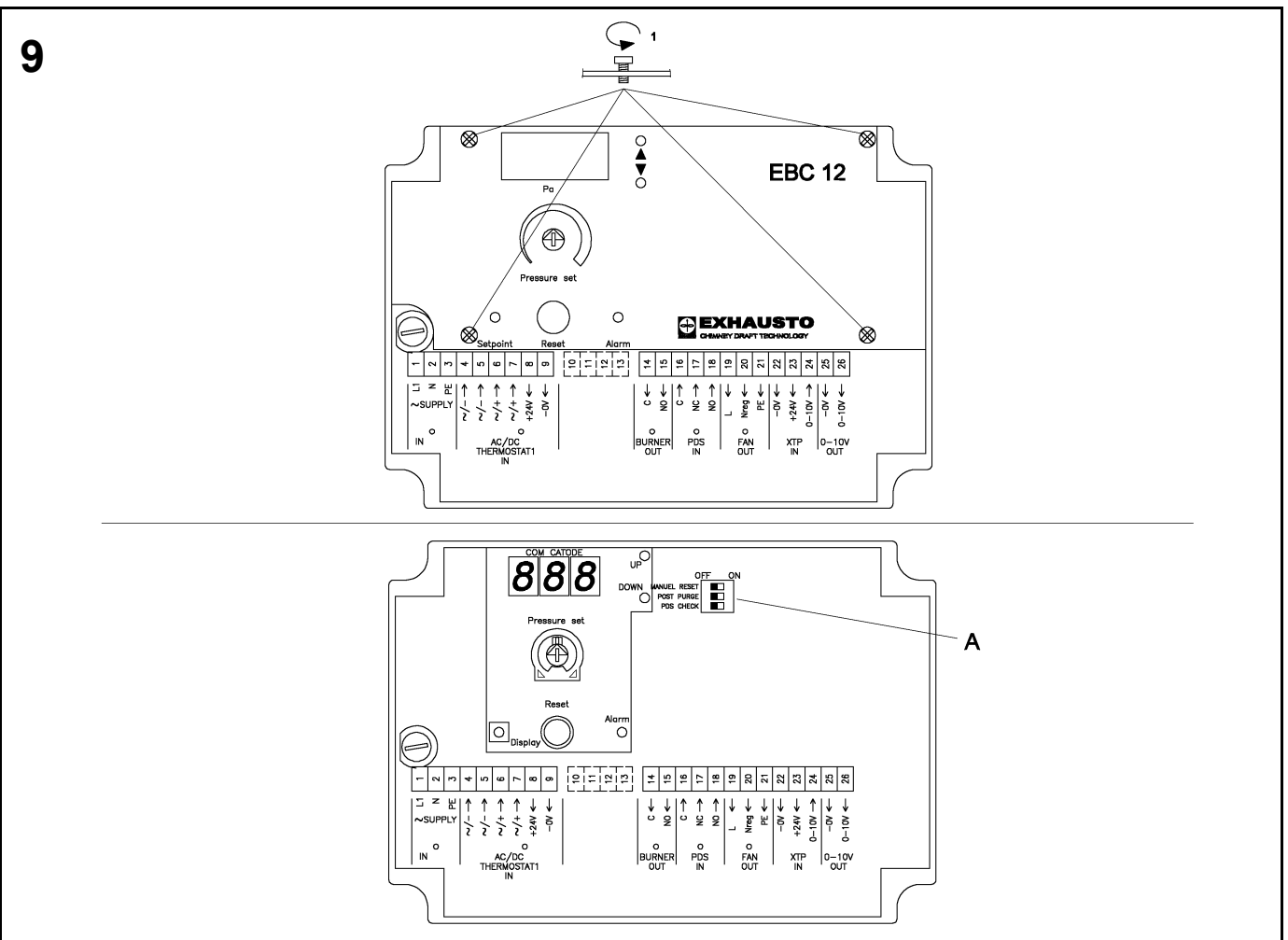

**2.4 Commissioning**

Commissioning must be carried out on the EBC12 to ensure a correct draught from the system.

Proceed as follows:

1. Provisional setting of draught.  
Push the setpoint button (fig. 10-B). The selected value will be shown on the display (fig. 10-D). By means of the potentiometer (fig. 10-C), adjustments are carried out, until the required under pressure is shown on the display (fig. 10-D). Release the setpoint button (Fig. 10-B).
2. Start the system and wait until the boiler thermostat (fig. 10-A) switches on and the draught has stabilised (up/down adjustment LEDs are not lit). The current draught is shown on the display (fig. 10-D).
3. Final setting of draught.  
Check the draught on the boiler and adjust as above if required.
4. Check that the fail-safe system cuts out the boiler. Faults can be simulated by removing the tube that goes to 'negative' on the pressure transducer (XTP). The LED (fig. 10-E) is turned off and the alarm LED (fig. 10-F) is turned on.
5. Check the start function after completing the initial adjustment. This is done by restarting the system.

Concerning setpoint values please refer to the data of each boiler, anyway the following may be considered as typical values.

- Boilers with forced draught: Typical 20 - 30 Pa
- Boilers with atmospheric burner: Typical 5 - 10 Pa

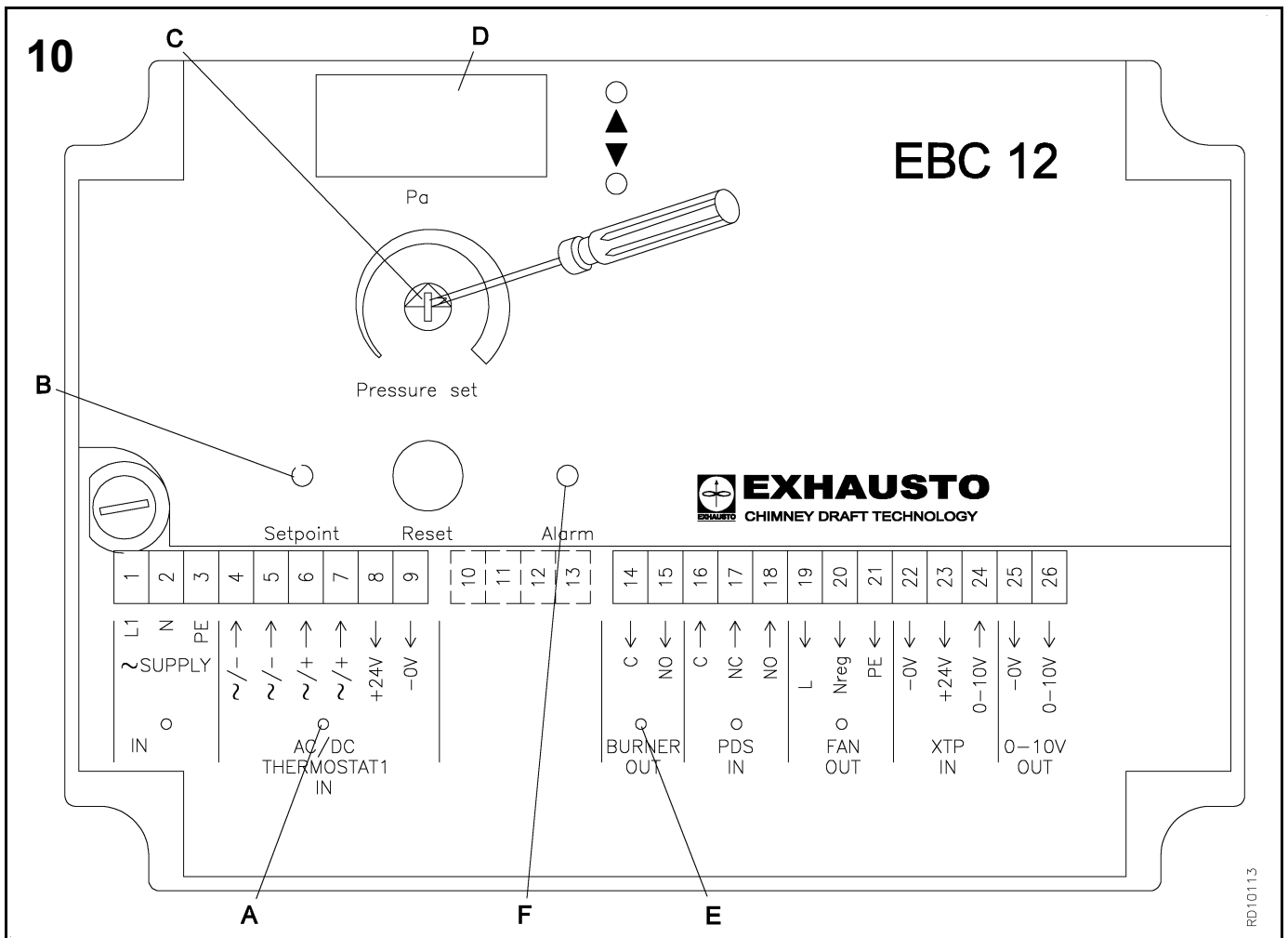

### 3 Fault finding

Observation	Fault type	Solution
The supply LED (fig.11-A) is not lit.	Defective fuse or no mains connection.	1) Check the fuse (fig. 11-B) and the chimney fan. 2) Check the wiring.
Permanent light in LED for Upwards regulation (fig. 11-D)	System fault.	1) Check that the probe is connected to the negative probe on the XTP pressure transducer. 2) Check that the probe has not been clogged up. <b>WARNING: Do not blow into the XTP pressure transducer.</b> 3) Check that the chimney fan is running 4) The selected value is higher than the chimney fan capacity. Check the setpoint setting. 5) Check the initial adjustment of the system. 6) Check the flue pipe duct and chimney for leaks. 7) Check the wiring of the XTP pressure transducer.
Permanent light in LED for Downwards regulation (fig. 11-E)	System fault.	1) The natural draught in the chimney prevents downwards regulation to the required setpoint. Check the setpoint setting. 2) The probe is in an unfortunate position. The probe may be moved to a better position.
Permanent light in ALARM LED (fig. 11-H). - No light in chimney fan LED (fig. 11-G) - (Only occurs if MANUAL RESET is ON (fig. 11-F)).	Mains drop-out (Current failure).	Press the RESET button for 1 sec. (fig. 11-C) - See warning.
Permanent light in ALARM LED (fig. 11-H) - Light in chimney fan (fig. 11-G).	No draught.	1) Press the RESET button for 1 sec. (fig. 11-C) - See warning. 2) Check the repair switch for the chimney fan. 3) Check the flue, chimney and chimney fan for any blocking items.
Flashing ALARM LED (fig. 11-H). - (Only occurs if PDS CHECK is ON (fig. 11-F)).	Failure in fail-safe supervision (PDS).	1) Check that a pressure differential switch has been fitted. 2) Check the setting of the fail-safe system (natural draught prevent cut-out/alternatively PDS-CHECK can be deselected on the dipswitch (fig. 11-F)). 3) Check the connection to the pressure differential switch and the pressure differential switch itself.



Some systems require a special start-up procedure after a safety cut-out. Follow this procedure before pressing the RESET button (fig. 11-C).

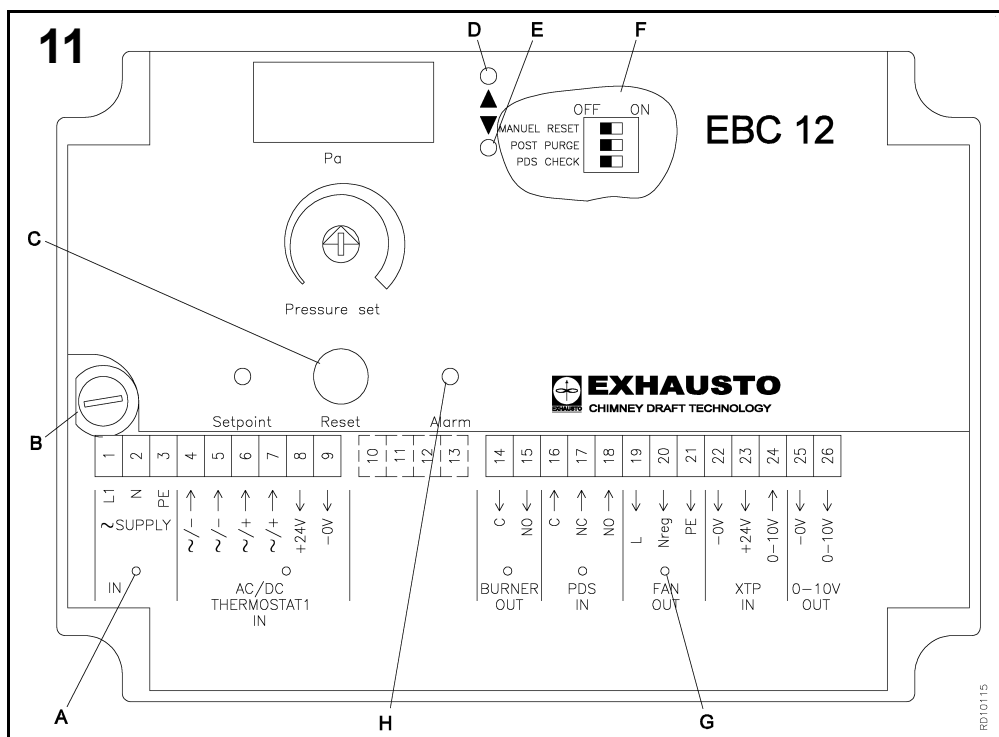

## 4 Technical data

### EBC12

Height x width x depth:	125mm x 175mm x 75mm
Degree of protection/material:	IP54/ABS box and polycarbonate cover
Supply voltage:	230V $\pm$ 10%
Fuse:	T5 A H 250V sand-filled
Ambient temperature:	-20°C to 50°C
Boiler output relay:	max. 8A/230V
Chimney fan output (AC3):	max. 3A/230 V
Control signal 0-10V:	max. 10 mA
Supply 0-24V (terminals 8-9):	max. 10 mA
Regulating range:	5 - 150 Pa

### XTP-Sensor

Height x width x depth:	74mm x 92mm x 49mm
Degree of protection:	IP54
Ambient temperature:	-20°C to 60°C

#### EXHAUSTO A/S

Odensevej 76  
DK-5550 Langeskov  
Tel.: +45 6566 1234  
Fax: +45 6566 1110  
exhausto@exhausto.dk  
www.exhausto.dk

#### EXHAUSTO AB

Verkstadsgatan 13  
S-542 33 Mariestad  
Tel.: +46 501 39 33 40  
Fax: +46 501 39 33 41  
info@exhausto.se  
www.exhausto.se

#### EXHAUSTO NORGE A/S

Lilleakerveien 4  
N-0283 Oslo  
Tel.: +47 2412 4200  
Fax: +47 2412 4201  
post@exhausto.no  
www.exhausto.no

#### EXHAUSTO GmbH

Am Ockenheimer Graben 40  
D-55411 Bingen-Kempton  
Tel.: +49 6721 9178-0  
Fax: +49 6721 9178-99  
info@exhausto.de  
www.exhausto.de

#### EXHAUSTO Ltd.

Unit 3 Lancaster Court  
Coronation Road  
Cressex Business Park  
High Wycombe HP12 3TD  
Tel.: +44 1494 465166  
Fax: +44 1494 465163  
info@exhausto.co.uk  
www.exhausto.co.uk

#### EXHAUSTO Inc.

1200 Northmeadow Parkway  
Suite 180  
Roswell, GA 30076 USA  
Tel.: +1 770 587 3238  
Fax: +1 770 587 4731  
service@exhausto.com  
www.us.exhausto.com