

## Chimney fan

# RSV



An Exodraft RSV chimney fan is a specially designed extractor fan with vertical discharge.

Exodraft chimney fans RSV160-450 are designed for boiler room installations up to 3 MW using a single fan. For larger boiler capacities several fans can be mounted on a plenum box.

The RSV160-450 can be used with heating appliances burning gas and oil.

The fans are installed on top of the chimney where the vertical discharge column prevents a plume of gas flowing down outside of the chimney.

Exodraft chimney fans RSV are used with heating appliances and provide a controllable negative pressure along the full length of the flue and chimney.

## Technical data

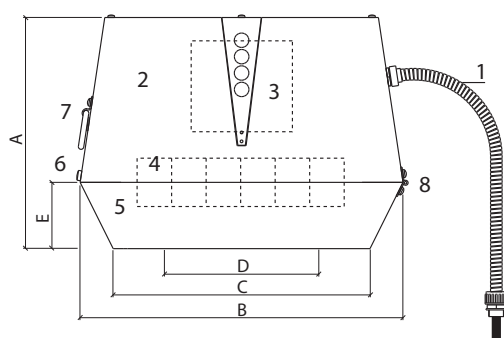

1. Connecting cable
2. Top section
3. Motor
4. Vane/centrifugal impeller
5. Bottom section
6. Locking screws
7. Handle
8. Hinges

Model	Motor data				Weight kg	Dimension (mm)				
	rpm	V	Amp	kW*		A	B x B	C x C	D Ø	E
RSV009-41	1400	1 x 230	0.14	0.05	13	250	310	240	215	70
RSV012-41	1400	1 x 230	0.35	0.13	17	280	390	310	275	80
RSV014-41	1400	1 x 230	0.80	0.16	24	335	485	385	335	100
RSV016-41	1400	1 x 230	1.80	0.32	35	380	580	465	365	115
RSV160-41	1400	1 x 230	0.40	0.04	12	250	310	240	160	70
RSV200-41	1400	1 x 230	0.40	0.07	18	280	390	310	200	80
RSV250-41	1400	1 x 230	0.80	0.16	27	335	485	385	250	100
RSV315-41	1400	1 x 230	1.80	0.37	37	380	580	465	315	115
RSV400-41	1400	1 x 230	2.60	0.40	47	430	650	525	400	130
RSV400-42**	1720	3 x 230	3.50	0.75	52	460	650	525	400	130
RSV450-42**	1720	3 x 230	6.50	1.50	58	590	650	525	400	220

\*Power consumption at ambient temperature of 20 °C

\*\*Frequency converter is required

The RPM of the above fan models are infinitely adjustable

Motor protection IP rating IP54

Insulation class F

## Capacity diagrams

### RSV009 to RSV016

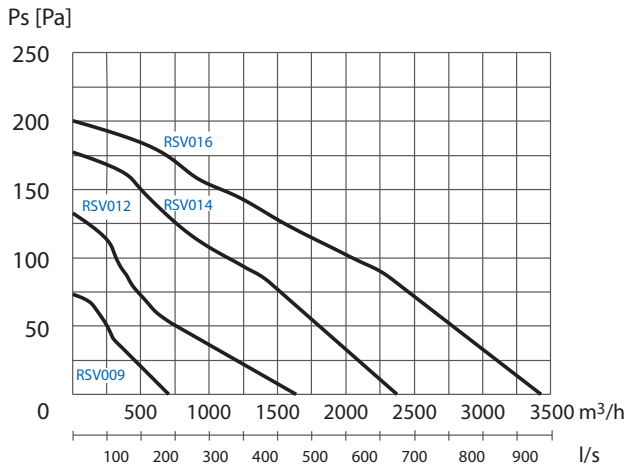

Type	Test flue diameters
RSV009	Ø 160 mm
RSV012	Ø 200 mm
RSV014	Ø 250 mm
RSV016	Ø 315 mm
RSV160	Ø 160 mm
RSV200	Ø 200 mm
RSV250	Ø 250 mm
RSV315	Ø 315 mm
at 1400 rpm	
RSV400	Ø 400 mm
RSV450	Ø 400 mm
at 1720 rpm	

### RSV160 to RSV400

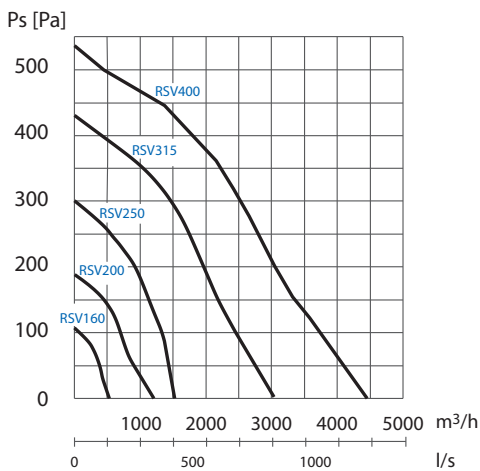

### RSV400-4-2 to RSV450-4-2

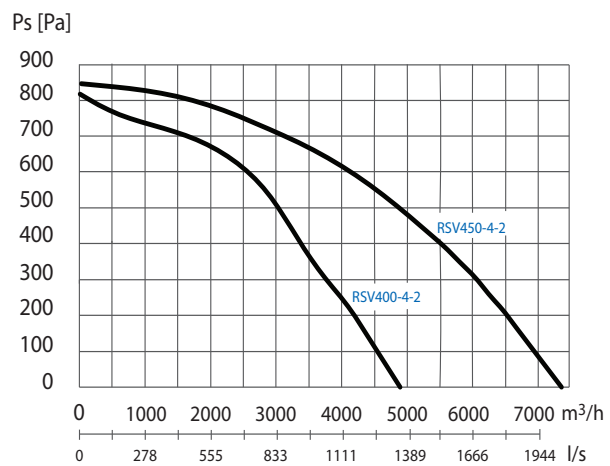

PLEASE NOTE: The capacity diagrams are measured with a flue gas temperature of 20 °C. The fan's capacity changes with the temperature of the flue gases. The correction of the capacity can be calculated using the following equation:

$$P_{S_{20}} = P_{S_t} \times \frac{273 + t}{293}$$

$P_S$  = static pressure  
 $t$  = temperature measured in °C

Example

System demand: 500 m³/h and 90 Pa at 180 °C

Fan selection: 500 m³/h and 139 Pa at 20 °C

## Sound data

Sound levels to external surroundings  
Lw (dB) measured in accordance with ISO 3744

Model	Lw (dB)							Lp dB (A)
	125 Hz	250 Hz	500 Hz	1000 Hz	2000 Hz	4000 Hz	8000 Hz	
RSV009-41	57	55	54	49	40	35	26	26
RSV012-41	64	62	61	55	51	46	40	33
RSV014-41	71	70	68	61	56	50	44	40
RSV016-41	76	76	70	65	60	55	49	44
RSV160-41	56	54	57	51	44	34	28	30
RSV200-41	64	62	61	55	51	46	40	33
RSV250-41	64	68	66	65	61	49	45	41
RSV315-41	71	75	70	73	68	57	52	48
RSV400-41	76	80	75	79	74	62	57	53
RSV400-42	87	82	76	76	68	62	58	57
RSV450-42	78	88	80	84	77	67	61	59

Tolerance +/- 3 dB

Lw = sound effect level dB (reference: 1 pW)

Lp = sound pressure level dB (A) at 10 m distance from the fan at half spheric sound distribution

Lp (5 m) = Lp (10 m) + 6 dB

Lp (20 m) = Lp (10 m) - 6 dB