

Flue gas and process heat

DAMPER MOTOR (DM)

The exodraft Damper Motor is used in exodraft exhaust system solutions for the protection or control of inflow of hot flue gas to Basic Plate heat recovery devices. A damper motor is used primarily for larger boiler systems, industrial processing plants, or commercial systems.

All parts in contact with flue gas are made from stainless steel EN 1.4404. All exterior parts are made from stainless steel EN 1.4301. An integrated electric motor opens and closes the flue. Two types: on/off or modulating motor.

Power supply and start/stop signal come from an external exodraft control, and thus is not part of the Damper Motor. The Damper Motor has a safety feature causing it to enter safety mode automatically in case of power failure.



Spare parts

- Gasket (2400046)
- Damper motor NFA 10 Nm (3201081)
- Damper motor NF24A-SZ 10 Nm (3201078)

General specifications

- Handles flue gas temperatures up to 600 °C
- Control: open-closed or modulating
- Normally closed with spring return safety function (can be changed to normally open with spring return safety function for different orientation)
- All parts in connection with flue gas made in stainless steel 316 (EN 1.4404)
- All external parts made in stainless steel 304 (EN 1.4301)
- 40 mm insulation
- Designed for indoor use. Can be used outside if the product is covered / encapsulated
- In conformance with 2006/42/EF
- In conformance with 2014/35/EU

Accessories

- Auxiliary switch unit for damper motors (3200984)

Models

Model	Item no.	Description	Max. temp [°C]	Inlet (Nipple) ø outside [mm]	Outlet (Sleeve) ø inside [mm]	Weight [kg]
DM350	8004500	On/off damper with motor Standard connecting pipe dimension - Max 600 °C	600	350.5	351.2	(62)
DM350-M	8004501	Modulating damper with motor Standard connecting pipe dimension - Max 600 °C	600	350.5	351.2	(62)
DM-400	8004600	Modulating damper with motor Standard connecting pipe dimension - Max 600 °C	600	400.5	401.2	(60)
DM400-M	8004601	Modulating damper with motor Standard connecting pipe dimension - Max 600 °C	600	400.5	401.2	(60)
DM500	8004700	On/off damper with motor Standard connecting pipe dimension - Max 600 °C	600	500.5	501.2	(58)
DM500-M	8004701	Modulating damper with motor Standard connecting pipe dimension - Max 600 °C	600	500.5	501.2	(58)

Dimensions

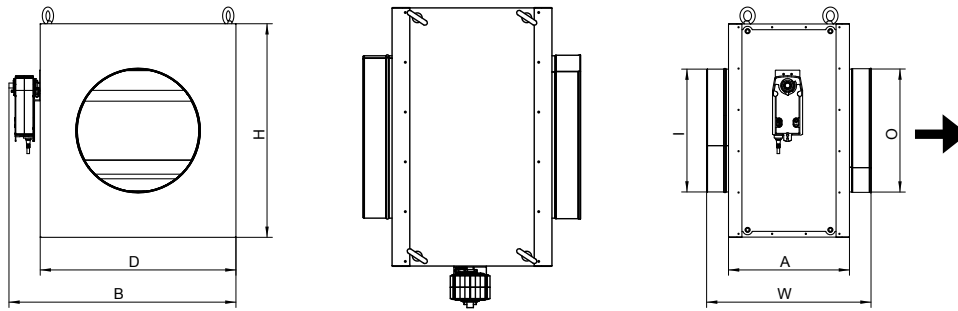

Model/Dimension	A	W	H	D	B	I*	O*	KG
DM350/DM350-M	394.4	536.1	696.4	638.2	740.3	350.5	351.2	(62)
DM400/DM400-M	394.4	536.1	696.4	638.2	740.3	400.5	401.2	(60)
DM500/DM500-M	394.4	536.1	696.4	638.2	740.3	500.5	501.2	(58)

*
I = Inlet with nipple coupling (outer measure)
O = Outlet with sleeve coupling (inner measure)

Damper motors

Compatibility	Model	Item no.	Nominal voltage	Max power consumption [W]	Standby power consumption [W]	Cable size
For DM350	NFA 10 Nm	3201081	AC 24 ... 240 V, 50 / 60 Hz / DC 24 ... 125 V	6	2.5	3 x 0.75mm ² (9.5 VA)
For DM350-M	NF24A-SZ 10 Nm	3201078	AC 24 V 50 / 60 Hz / DC 24 V	3.5	2.5	3 x 0.75mm ² (5.5 VA)
For DM400	NFA 10 Nm	3201081	AC 24 ... 240 V, 50 / 60 Hz / DC 24 ... 125 V	6	2.5	3 x 0.75mm ² (9.5 VA)
For DM400-M	NF24A-SZ 10 Nm	3201078	AC 24 V 50 / 60 Hz / DC 24 V	3.5	2.5	3 x 0.75mm ² (9.5 VA)
For DM500	NFA 10 Nm	3201081	AC 24 ... 240 V, 50 / 60 Hz / DC 24 ... 125 V	6	2.5	3 x 0.75mm ² (9.5 VA)
For DM500-M	NF24A-SZ 10 Nm	3201078	AC 24 V 50 / 60 Hz / DC 24 V	3.5	2.5	3 x 0.75mm ² (5.5 VA)